

# In-line Refractometer

Model : GND15



## Instruction manual



**ENERGIA Y AUTOMATIZACION**

Thank you for purchasing an in-line refractometer. This instruction manual is designed with ENAU Spa to guide you to understand the functions and characteristics of the sensor. Before using the instrument, please read this manual carefully to ensure safe and correct use. Please keep this manual for future reference

# In-line Refractometer

## Model : GND15

### Description

The In-line Brix-Monitor GND15 is a refractometer that detects the Refractive Index of a sample and outputs the Brix(%) value on the display , can also transmit measured data to external devices via 4 to 20mA or RS-232C. GND15 series has the function of automatic temperature compensation according to the temperature of the tested medium , when the tested medium temperature changes , the Brix value ( soluble solids ) after temperature compensation is displays and the output changes accordingly

### What is refractometer ?

When a straw is placed into a glass filled with water, the straw appears to bend. When a straw is placed into a glass filled with sugar water, the straw appears to bend much more sharply than in the case of water alone. This phenomenon is known as the refraction of light. The refractometer is an instrument that measures the Refractive Index by utilizing this principle (the Refractive Index increases in proportion to the concentration of the solution), and was developed by Dr. Ernst Abbe at the end of the 19th century.

### Working Principle

If the Refractive Index of air under atmospheric pressure is 1, then when light enters medium  $\chi$ , the ratio of the sine of the incident angle  $\alpha$  measured against the phase boundary to the sine of the refracting angle  $\beta$  is called the Refractive Index of the medium  $\chi$ .

The Refractive Index varies with the wavelength of light and temperature and is represented as follows:

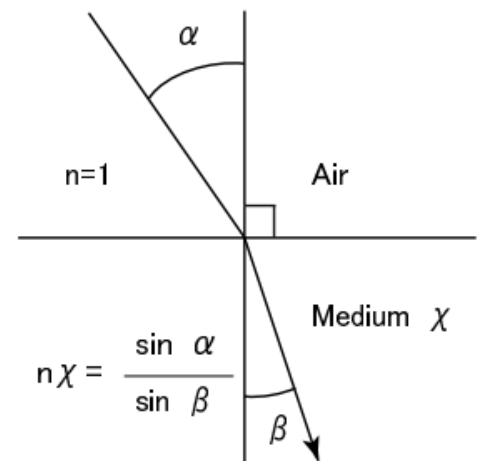

n :	Represents the Refractive Index
t :	Temperature (°C)
D :	D-line of natrium (589nm)

For example, Refractive Index of water at 20°C under the D-line is:  $n_D^{20} = 1.33299$  , (Generally expressed as  $n_D = 1.33299$ .)

**Note :** The Refractive Index is based upon the supposition that the Refractive Index in a vacuum is 1 and is called the absolute Refractive Index. Generally, however, this index is seldom used.

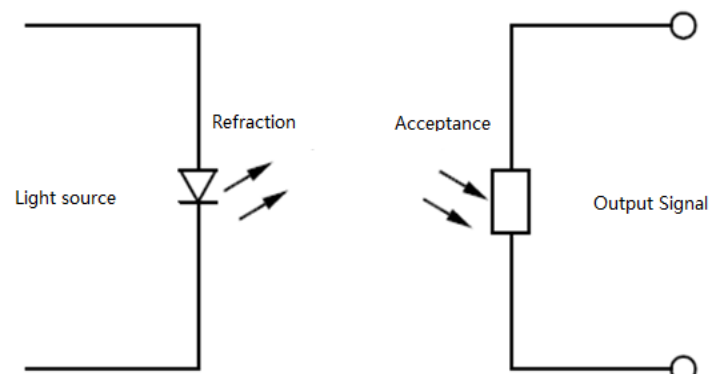
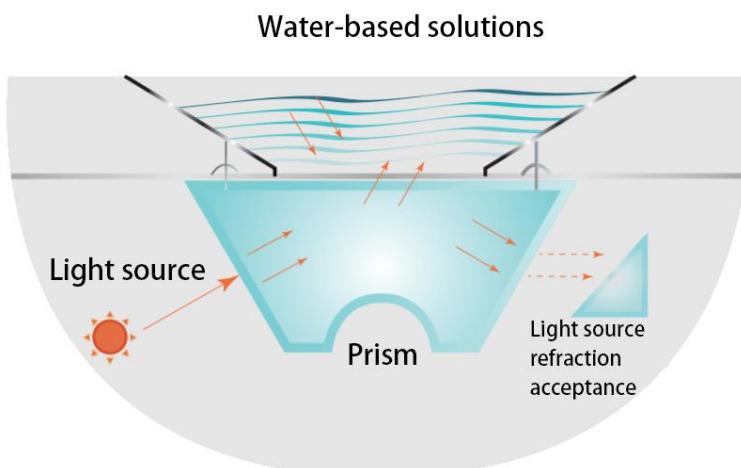

# In-line Refractometer

## Model : GND15

### **Brix(%) scale**

The GND15 is programmed with the Brix(%) scale, based on the Refractive Index of water ( $n_D = 1.33299$ ), as the reference (0%). The Brix(%) scale represents the weight of sucrose expressed by percentage (sucrose weight in grams contained in 100 grams of sucrose solution).

Therefore, this scale corresponds with the sucrose concentration. However, most samples are comprised of ingredients other than sugar. The total concentration of these ingredients is represented by the Brix(%), so this makes the Brix(%) scale a practical tool for measuring concentrations.

**Note :** The Brix(%) scale is recommended by ICUMSA (International Committee of Uniform Method of Sugar Analysis) and is expressed in % mas (Sucrose) in international units (SI unit).

The relationship between Brix(%) and the Refractive Index ( $n_D$ ) is outlined on page 4

### **Temperature correction**

The Refractive Index of a substance varies with temperature. Thus, when using a refractometer to measure the Refractive Index of a liquid, the measurement value will vary with the sample temperature. The GND15 always detects the prism temperature. The value of the measurement is automatically corrected for temperature by a built-in processor, so that the displayed value is equal to the value measured at 20°C (provided that the sample temperature is within the range of 5 to 100°C).

### **Temperature compensation**

The GND15 constantly detects the temperature of the prism. When the sample temperature is within the range of 5 to 100°C, the Brix(%) values are automatically compensated for temperature

### **Features**

- ◆ Automatic temperature compensation
- ◆ Lightweight, compact and easy to install on site.
- ◆ LED display,
- ◆ Easy to operate, easy to connect with other devices for automatic control
- ◆ Inline real-time monitoring and control of liquid substance concentration in various industries

### **Applications**

- ◆ Cutting oil, mold release agent, quenching liquid, cleaning liquid, emulsion in the machining industry
- ◆ Chemicals and allied, pulp & paper, tobacco, environmental protection
- ◆ Biorefining, Metals and mining
- ◆ Food industry, Dairy, Beverage industry, Fruit and effect processing,
- ◆ Starch sweetener, Sugar and sweeteners
- ◆ Water-based solutions

# In-line Refractometer

## Model : GND15



### Relationships between Brix(%) Values and Refractive Index (nD) Values

%	n <sub>D</sub> <sup>20</sup>	%	n <sub>D</sub> <sup>20</sup>	%	n <sub>D</sub> <sup>20</sup>	%	n <sub>D</sub> <sup>20</sup>
0	1.33299	22	1.36720	44	1.40776		
1	1.33442	23	1.36889	45	1.40978	66	1.45584
2	1.33586	24	1.37060	46	1.41181	67	1.45822
3	1.33732	25	1.37233	47	1.41385	68	1.46061
4	1.33879	26	1.37406	48	1.41592	69	1.46303
5	1.34026	27	1.37582	49	1.41799	70	1.46546
6	1.34175	28	1.37758	50	1.42009	71	1.46790
7	1.34325	29	1.37936	51	1.42220	72	1.47037
8	1.34477	30	1.38115	52	1.42432	73	1.47285
9	1.34629	31	1.38296	53	1.42647	74	1.47535
10	1.34782	32	1.38478	54	1.42863	75	1.47787
11	1.34937	33	1.38661	55	1.43080	76	1.48040
12	1.35093	34	1.38846	56	1.43299	77	1.48295
13	1.35250	35	1.39032	57	1.43520	78	1.48552
14	1.35408	36	1.39220	58	1.43743	79	1.48811
15	1.35568	37	1.39409	59	1.43967	80	1.49071
16	1.35729	38	1.39600	60	1.44193	81	1.49333
17	1.35891	39	1.39792	61	1.44420	82	1.49597
18	1.36054	40	1.39986	62	1.44650	83	1.49862
19	1.36218	41	1.40181	63	1.44881	84	1.50129
20	1.36384	42	1.40378	64	1.45113	85	1.50398
21	1.36551	43	1.40576	65	1.45348		

# In-line Refractometer

## Model : GND15

**Table of temperature correction values for sucrose (g/100g) for refractometer (reference at 20°C, 589nm)**

T (°C)	Sucrose (g/100g)																		
	0	5	10	15	20	25	30	35	40	45	50	55	60	65	70	75	80	85	
15	-0.29	-0.3	-0.32	-0.33	-0.34	-0.35	-0.36	-0.37	-0.37	-0.38	-0.38	-0.38	-0.38	-0.38	-0.38	-0.37	-0.37		
16	-0.24	-0.25	-0.26	-0.27	-0.28	-0.28	-0.29	-0.3	-0.3	-0.3	-0.31	-0.31	-0.31	-0.31	-0.31	-0.3	-0.3	-0.3	
17	-0.18	-0.19	-0.2	-0.2	-0.21	-0.21	-0.22	-0.22	-0.23	-0.23	-0.23	-0.23	-0.23	-0.23	-0.23	-0.23	-0.23	-0.22	
18	-0.12	-0.13	-0.13	-0.14	-0.14	-0.14	-0.15	-0.15	-0.15	-0.15	-0.15	-0.15	-0.15	-0.15	-0.15	-0.15	-0.15	-0.15	
19	-0.06	-0.06	-0.07	-0.07	-0.07	-0.07	-0.07	-0.08	-0.08	-0.08	-0.08	-0.08	-0.08	-0.08	-0.08	-0.08	-0.08	-0.07	
20	0	0	0	0	0	0	0	0	0	0	0	0	0	0	0	0	0	0	
21	0.06	0.07	0.07	0.07	0.07	0.07	0.08	0.08	0.08	0.08	0.08	0.08	0.08	0.08	0.08	0.08	0.08	0.07	
22	0.13	0.14	0.14	0.14	0.15	0.15	0.15	0.15	0.16	0.16	0.16	0.16	0.16	0.16	0.15	0.15	0.15	0.15	
23	0.2	0.21	0.21	0.22	0.22	0.23	0.23	0.23	0.23	0.24	0.24	0.24	0.24	0.23	0.23	0.23	0.23	0.22	
24	0.27	0.28	0.29	0.29	0.3	0.3	0.31	0.31	0.31	0.32	0.32	0.32	0.32	0.31	0.31	0.31	0.3	0.3	
25	0.34	0.35	0.36	0.37	0.38	0.38	0.39	0.39	0.4	0.4	0.4	0.4	0.4	0.39	0.39	0.38	0.38	0.37	
26	0.42	0.43	0.44	0.45	0.46	0.46	0.47	0.47	0.48	0.48	0.48	0.48	0.48	0.47	0.47	0.46	0.46	0.45	
27	0.5	0.51	0.52	0.53	0.54	0.55	0.55	0.56	0.56	0.56	0.56	0.56	0.56	0.55	0.55	0.54	0.53	0.52	
28	0.58	0.59	0.6	0.61	0.62	0.63	0.64	0.64	0.64	0.65	0.65	0.64	0.64	0.63	0.63	0.62	0.61	0.6	
29	0.66	0.67	0.68	0.7	0.71	0.71	0.72	0.73	0.73	0.73	0.73	0.73	0.72	0.72	0.71	0.7	0.69	0.67	
30	0.74	0.76	0.77	0.78	0.79	0.8	0.81	0.81	0.82	0.82	0.81	0.81	0.8	0.8	0.79	0.78	0.76	0.75	
31	0.83	0.84	0.85	0.87	0.88	0.89	0.89	0.9	0.9	0.9	0.9	0.89	0.89	0.88	0.87	0.86	0.84	0.82	
32	0.92	0.93	0.94	0.96	0.97	0.98	0.98	0.99	0.99	0.99	0.99	0.98	0.97	0.96	0.95	0.93	0.92	0.9	
33	1.01	1.02	1.03	1.05	1.06	1.07	1.07	1.08	1.08	1.08	1.07	1.07	1.06	1.04	1.03	1.01	1	0.98	
34	1.1	1.11	1.13	1.14	1.15	1.16	1.16	1.17	1.17	1.16	1.16	1.15	1.14	1.13	1.11	1.09	1.07	1.05	
35	1.19	1.21	1.22	1.23	1.24	1.25	1.25	1.26	1.26	1.25	1.25	1.24	1.23	1.21	1.19	1.17	1.15	1.13	
36	1.29	1.3	1.31	1.33	1.34	1.34	1.35	1.35	1.35	1.34	1.34	1.33	1.31	1.29	1.28	1.25	1.23	1.2	
37	1.39	1.4	1.41	1.42	1.43	1.44	1.44	1.44	1.44	1.43	1.43	1.41	1.4	1.38	1.36	1.33	1.31	1.28	
38	1.49	1.5	1.51	1.52	1.53	1.53	1.54	1.54	1.53	1.53	1.52	1.52	1.48	1.46	1.44	1.42	1.39	1.36	
39	1.59	1.6	1.61	1.62	1.63	1.63	1.63	1.63	1.63	1.62	1.61	1.59	1.57	1.55	1.52	1.5	1.47	1.43	
40	1.69	1.7	1.71	1.72	1.73	1.73	1.73	1.73	1.72	1.71	1.7	1.68	1.66	1.63	1.61	1.58	1.54	1.51	

# In-line Refractometer

## Model : GND15

### Specification

Model:	GND15
Measure Parameters:	Refractive index(nD), Brix (%), Temperature (° C)
Measure range:	0-15% , 0-33% , 0-53% , 93%
Resolution Ratio:	Brix: 0.01%, nD: 0.00001
Measurement Accuracy:	Brix: ±0.1%, nD: ±0.0001, Brix: ±0.25%, nD: ±0.0025, Brix: ±0.5%, nD: ±0.0005,
Measurement Temperature:	0-120°C (Automatic Temperature Compensation)
Operating current:	≤200mA
Display menu:	Refractive index(nD) , Brix(%), Temperature (° C)
Output :	4-20mA , RS485 optional
Power:	24V DC
Wetted parts material:	Prism: sapphire, Prism stage: SS304 , SS316L (can be customized)
Optical source:	LED(the wave length approximate to D line)
Max Pressure:	1MPa
Environment Temperature:	0-40°C
Protection grade:	IP67
Instrument Size:	175mm*120mm*80mm
Process connection	3" tri-clamp , other size customized
High and low limit settings	Buttons can be set
Recorder output cable	2M ,3M ,5M,10M optional
Temperature sensor	Thin film platinum sensor

# In-line Refractometer

Model : GND15



## Dimension

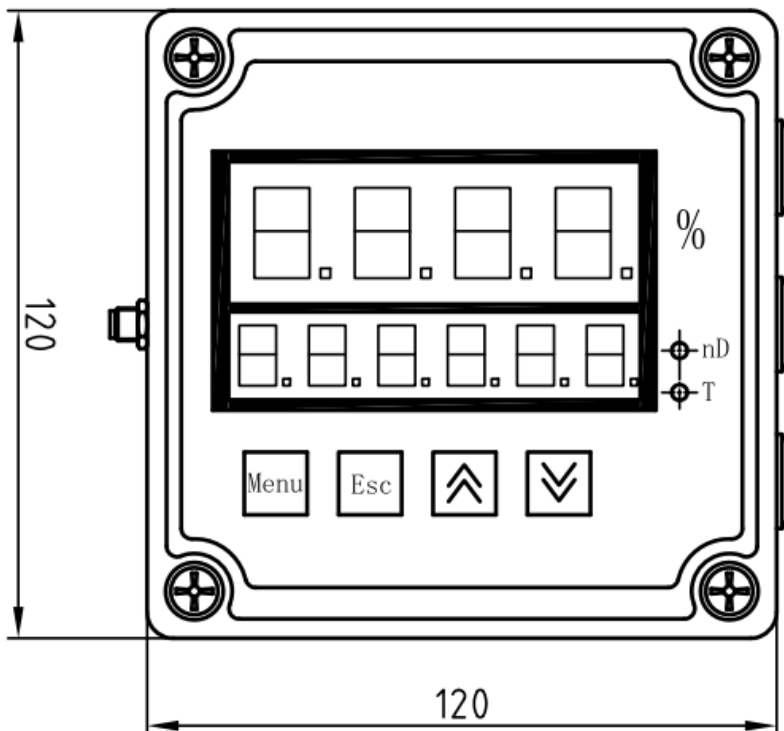
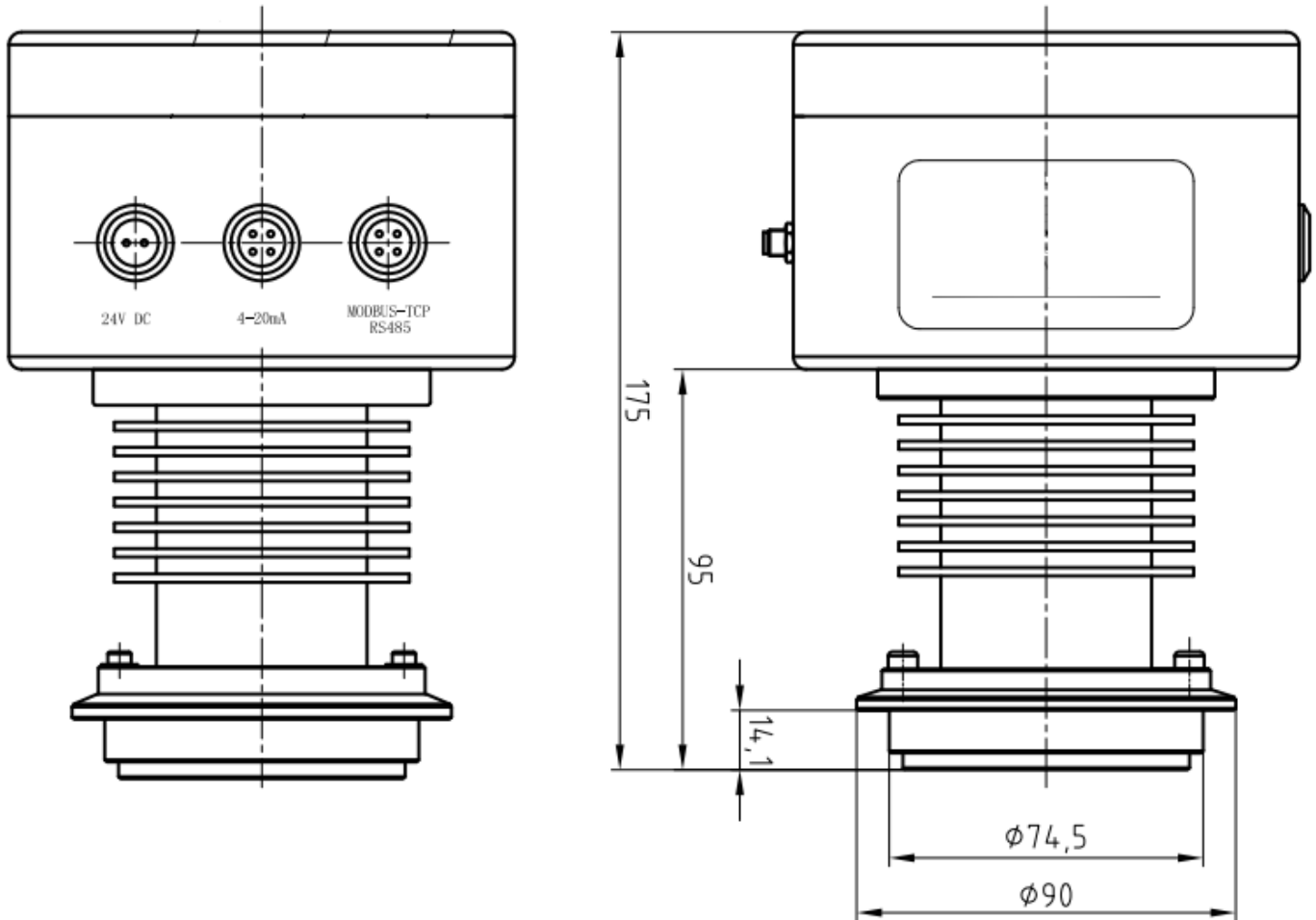

# In-line Refractometer

## Model : GND15

### Names and Functions of Components

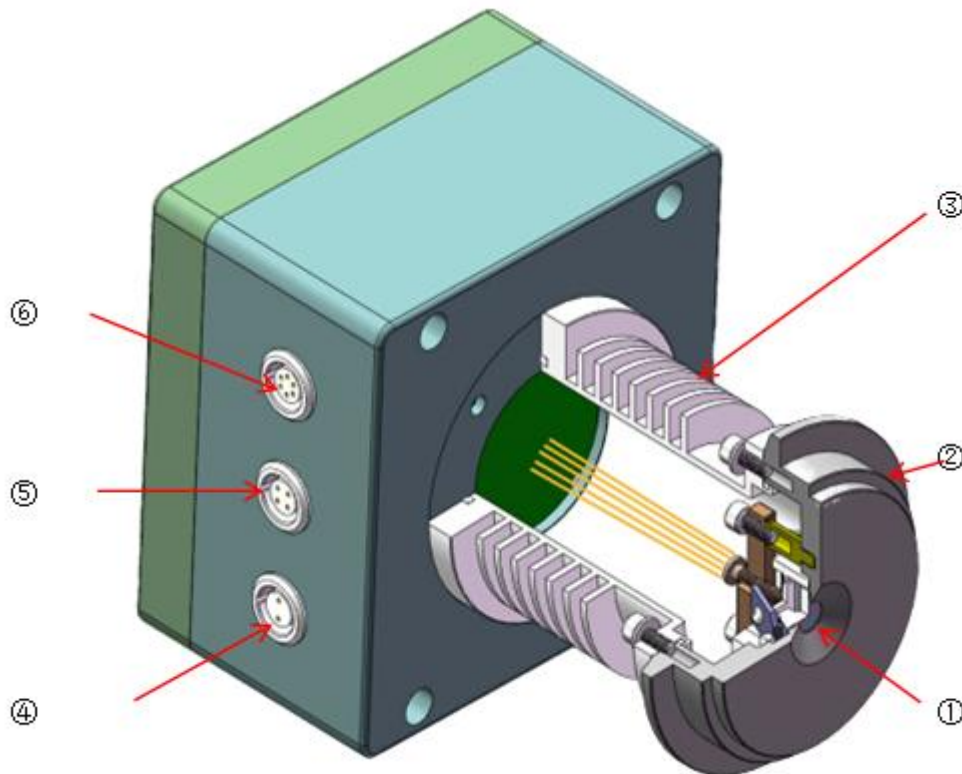

- ① Prism : Corrosion resistant optical glass, with a polished surface to reflect light.
- ② Prism stage :Connected to the sample inlet and fastened by a O-Ring and clamp band .
- ③ Radiator: Disperses heat when measuring high temperature samples to prevent the electric circuit from overheating.
- ④ 2-pins plug for unit power (24VDC)
- ⑤ 4-pins plug for output ( 4-20mA ) , connect to a recorder.
- ⑥ 4-pins plug for output ( Modbus-TCP RS485), connect to a computer.

**Note:** our GND15 as no power switch. Turn off the power (DC24V) prior to connecting cables to the individual units. When power is supplied to the GND15 , The Brix(%) value will be displayed when sample flows onto the prism surface, the measurement value display illuminates , the unit work commences. If there is no sample on the prism surface (only air), the error message [LLLL] will be displayed.

**Caution :** NEVER connect the GND15 to power other than DC24 fluctuation is  $\pm 10\%$ ).



# In-line Refractometer

## Model : GND15

### Plug wiring definition

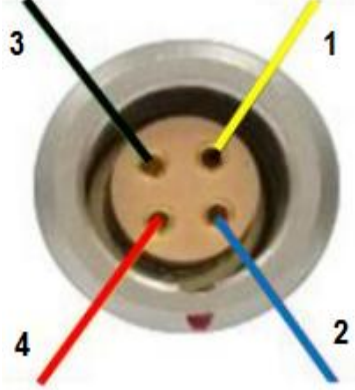
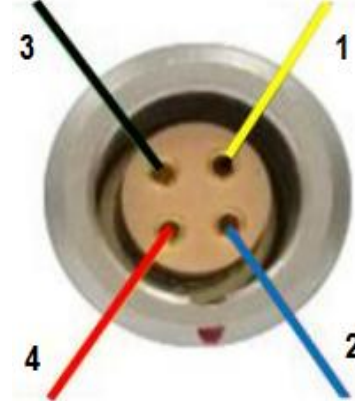
<p>2-pins plug for unit power (24VDC)</p>		<p>Pin1: 24V Power + , Red Pin 2: 24V Power - , Black</p>
<p>4-pins plug for output ( 4-20mA )</p>		<p>Pin 1: 4-20mA+ , Blue Pin 2: 4-20mA- , Yellow Pin 3 : NC Pin 4 : NC</p>
<p>4-pins plug for output ( Modbus-TCP RS485)</p>		<p>Pin 1: RS485A , Blue Pin 2: RS485B , , Yellow Pin 3 : NC Pin 4 : NC</p>

## Names and Functions of keys



- ① Measurement brix value display : Digitally displays the measurement value [Brix(%)], setting mode, and other setting values.
- ② Measurement value display : Digital switch displays the measure value [ nD and T]
- ③ Menu: Switches or sets the display mode of the measurement value and the setting mode, and save the setting value .
- ④ ESC: Exit key
- ⑤  $\wedge$ : Up keys : Increase the value in each setting mode.
- ⑥  $\vee$ : Down key: decrease the value in each setting mode .

### Button definition and operation

In the measurement interface, press Menu to enter the first level menu, and ESC to return to the measurement interface. Under the first level menu, you can use the up and down keys to select the corresponding options. When you press Menu, you will enter the second level menu. The up and down keys will adjust the corresponding options. After adjustment, press Menu to save the settings and return to the first level menu. After adjustment, press ESC to not save and Return to the first level menu.

	First level menu	Second level menu
1	Measurement interval	4,6,8,10 S
2	Calibrate 0	Calibration 0 returns to the main page successfully, EE0 is displayed if it fails
3	Brix corresponding to the upper limit of 20mA in the current 4~20mA	Default value depend on the measurement range
4	Decimal places	0 , 1 , 2
5	Display temperature, refractive index or polling display	1=temperature, 2=refractive index, 3=polling display
6	Mode-S measurement stability	1, 2, 3, 4, 5 total 5 gears
7	Temperature correction in units of 0.1	Increase or decrease by 0.1
8	Brix corresponding to the lower limit 4mA in the current 4-20mA	Default 0%
9	Temperature 4-20mA upper limit 1 as the unit	Increase or decrease the upper limit of the solution 4-20mA output by 1. When the temperature value is greater than or equal to the upper limit, the output is 20mA, and the value range is -10-130
10	Temperature 4-20mA lower limit 1 as the unit	Increment or decrement the lower limit of the 4-20mA output of the solution by 1, when the temperature value $\geq$ the upper limit, the output 4mA, the value range is -10-130
11	The alarm high limit is 1 as the unit	When the measured concentration exceeds the high limit, the display flashes quickly, and the value range is 0-100 When the setting value is greater than 95, it is equivalent to turning off the alarm output
12	Alarm low limit 1 as unit	Increase or decrease by 1 when the measured concentration is lower than the low limit, display Slow flashing, when the set value is less than 0, it is equivalent to turning off the alarm output
13	Device ID address	Default is 1
14	Reset	Return to the main page after successful reset, display EE1 on failure

# In-line Refractometer

## Model : GND15

### Operation instructions

- Step ① : Wipe the prism surface clean before starting the measurement
- Step ② : Connect the power to GND15 the measurement starts .
- Step ③ : Calibrate 0 with distilled water ( The factory Settings of the product have been validated )
- Step ④ : Install well our GND15 on the location that needs to be measure .
- Step ⑤ : When the sample flows into the prism surface
- Step ⑥: measurement starts , brix (%) value and current temperature T will be displayed .

### Screen display code definition

#### Boot display

[-----]  
[-----]

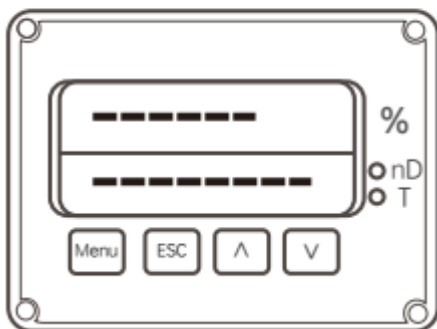

#### No solution display

LLLL  
T (Current Temperature)

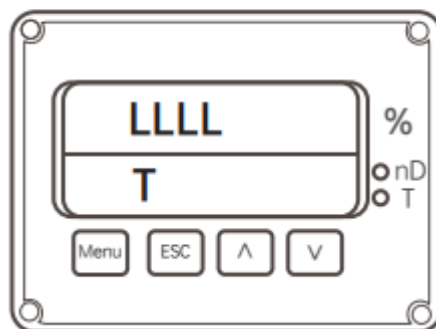

#### Brix exceeds the measuring range

HHHH  
T (Current temperature)

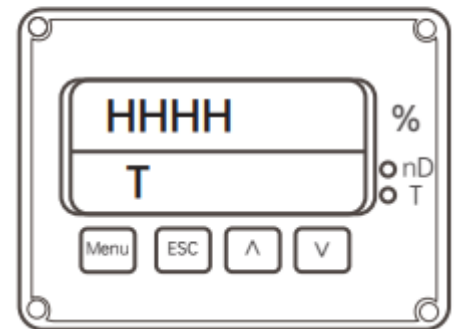

#### Normal measurement display

\*\*\* (Current Brix)

T (Current Temperature)

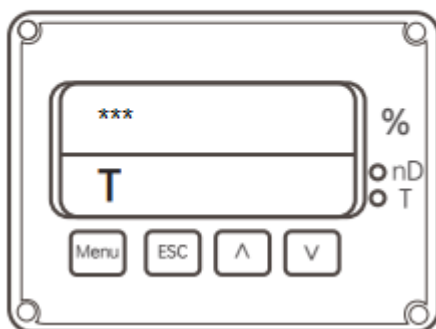

#### nD & T polling display

You can choose to display only T or nD or both through the menu.

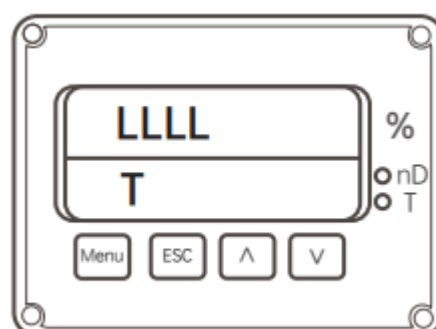

#### Calibration 0 failure display EE0

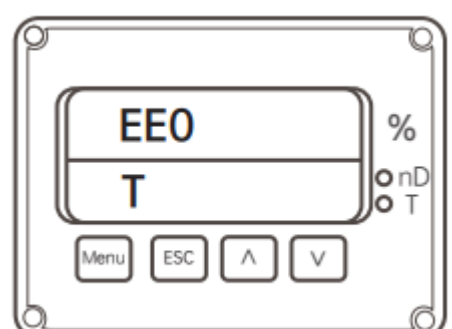

# In-line Refractometer

## Model : GND15

### Mounting Precautions

- ◆ The installation form of this product is a hoop quick-installation type;
- ◆ When installing, please pay special attention not to scratch the prism and probe;
- ◆ When installing, please pay special attention to avoid strong impact on the instrument;
- ◆ When installing, please pay special attention not to miss the sealing ring;
- ◆ Ensure that the cable is correctly connected to the port;
- ◆ The power can be turned on only after the product is installed;
- ◆ Immediately turn off the power (DC24V) if the unit begins to overheat, smoke or emit an abnormal smell.

### Mounting type 1: Compact small pipe installation

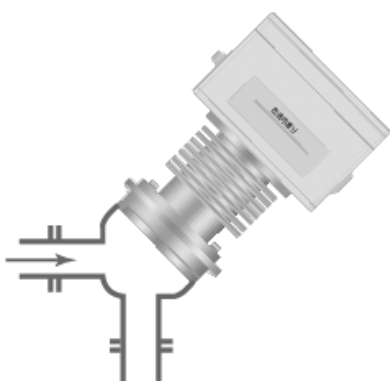

Small curve pipe

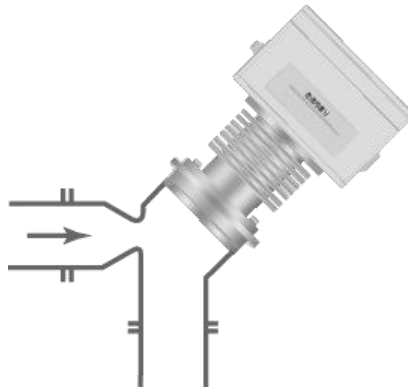

Neck to increase flow rate pipe

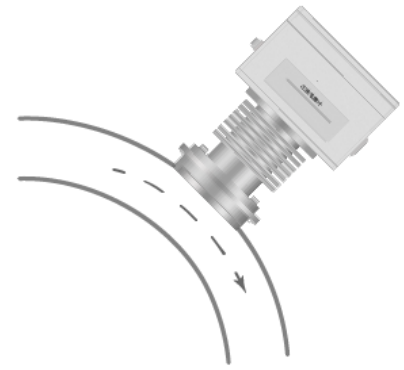

Normal curve pipe

### Mounting type 2: Large pipeline and container installation

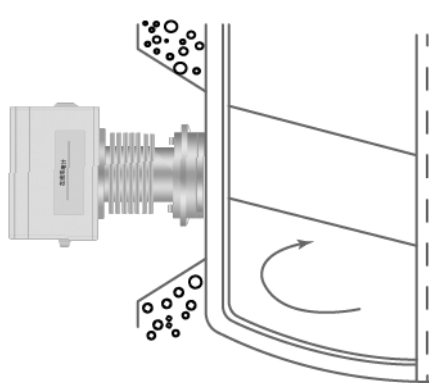

Digester with scraper and steam

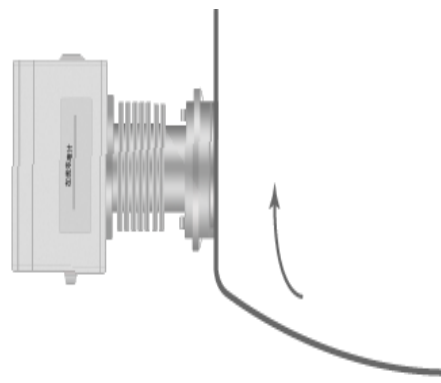

Container

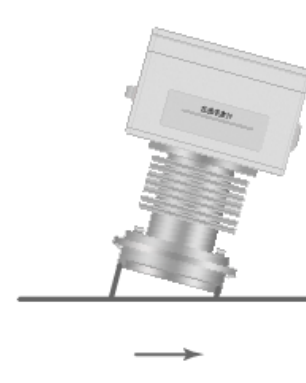

Big pipe

# In-line Refractometer

## Model : GND15

### Mounting procedure:

- ① Install the GND15 so that the prism surface is at a right angle to the ground.
- ② Attach the flow pipe to the GND15 with O-ring (accessory) inserted between them, and fasten them together with the clamp band (accessory).
- ③ The prism surface may become contaminated with solids, dirt and/or grease. If this happens, the prism surface must be cleaned by hand.

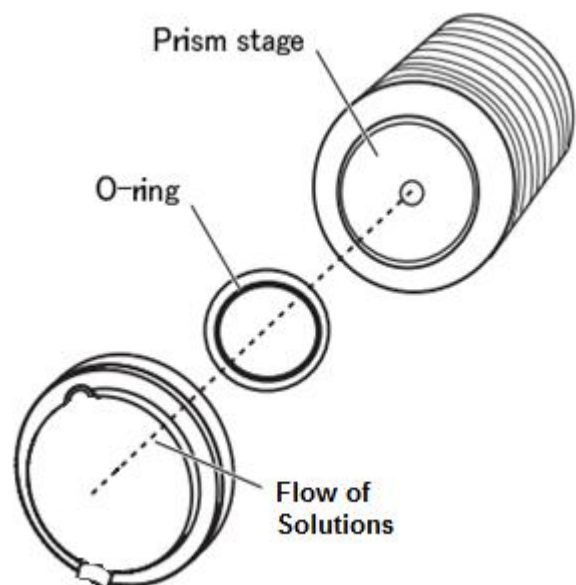

**Note :** Cleaning the Prism instruction in the next page

The sample inlet unit should be installed in such a manner that it can be easily removed to allow access to the prism for cleaning

**Note :** Suspending the GND15 (2.5kg) when using the sample inlet unit to connect to the piping is dangerous , Use of the optional stand is recommended.

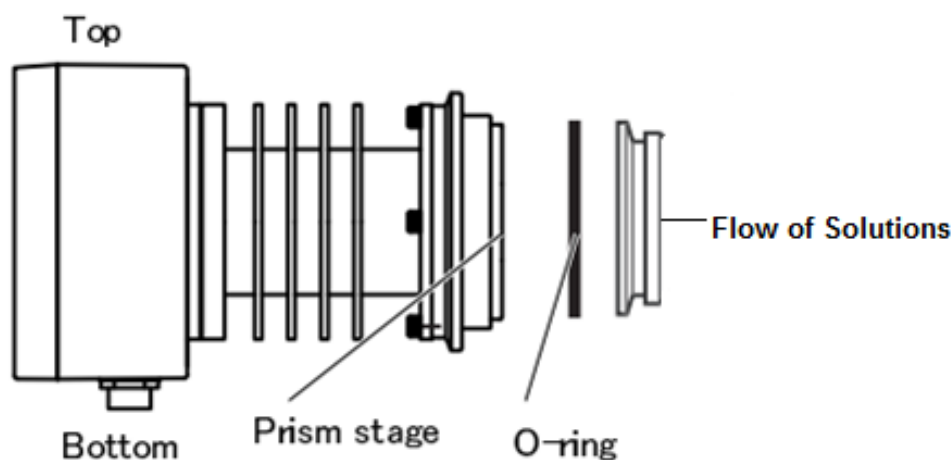
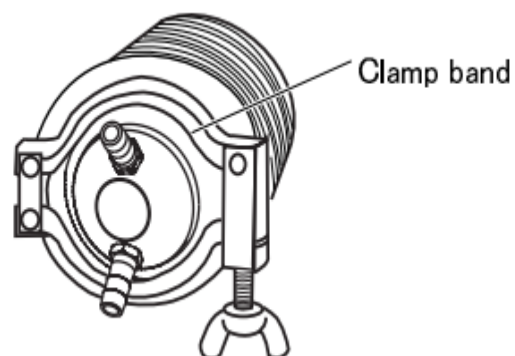

# In-line Refractometer

## Model : GND15

### Cleaning the Prism

- ◆ If the sample solution could potentially stain the prism, immediately clean the prism after measurement .
- ◆ Before running hazardous substance(s) through any precautions should be taken to ensure the safe handling of the hazardous system, necessary substance(s). If using a sample inlet unit, use caution when disconnecting the GND15 .
- ◆ Cleaning liquids up to 150°C can be used for CIP or SIP . The cleaning liquid can be used safely for 30 minutes at one time. The momentary difference between the sample liquid temperature and the cleaning liquid temperature must be no more than 80°C . When using cleaning liquids at temperatures over 150°C , the power source (DC24V) must be turned off.
- ◆ Detach the clamp band that connects the main unit to the sample inlet unit, piping or tank.
- ◆ Clean the prism surface carefully with a soft tissue soaked with warm water or ethyl alcohol. If the sample solution contains oil or grease, use ethyl alcohol to ensure the prism surface does not develop a film. Development of a film on the prism could cause erroneous measurements.
- ◆ NEVER clean the prism with an abrasive material.
- ◆ Cleaning the prism with an abrasive material could cause scratches on the prism which could lead to erroneous measurements.
- ◆ After cleaning is complete, re-attach the GND15 unit to the sample inlet unit, piping or tank. The procedure is described on the instruction manual.

**Note : Note : we also can supply Auto or manual washing device (optional):** .auto washing device as follows :



# In-line Refractometer

## Model : GND15



### Environmental conditions

- ◆ If the unit begins to overheat, smoke, or emit an abnormal smell , immediately turn off the power and unplug the unit from the power supply.
- ◆ DO NOT measure any sample that can damage the prism or the sample inlet unit , sample temperature should be kept between 5°C and 100°C when the power is turned on .
- ◆ Do not put the instrument in a damp place, Maximum average relative humidity: 95% RH (25°C);
- ◆ Atmospheric pressure: 80kPa ~ 106kPa;
- ◆ Places where there is no corrosion or destruction of insulating gas, steam or dust;
- ◆ Use the instrument at altitudes below 2000 meters (altitude).
- ◆ Use the instrument indoor.
- ◆ Do not change the ambient temperature of the instrument suddenly
- ◆ Do not use instrument in areas with large amount dust and strong vibrations
- ◆ Do not put the instrument in low temperature place
- ◆ Do not put heavy objects on the instrument
- ◆ Do not install the instrument In direct sunlight or near the heating source.

### Breakdowns And Trouble Shooting :

If measurement of concentration transmitter is abnormal, please check input power supply first. If power supply is ok, check if the measurement window of transmitter has been covered by contamination or not, and make sure that measurement window can contact solution well at the mean time. If it is problem of transmitter itself, please return it to the factory for maintenance.

### Caution :

- ◆ Protected from direct rain and snow, the packaged transmitter can be applied to various modes of transportation, such as water, land and air transportation.
- ◆ The packaged transmitter can be stored for more than 12 months with temperature ranging from -40°C~60°C, and relative humidity less than 90%
- ◆ Live plug-in and pull-out should be strictly prohibited under live working condition, otherwise, it will damage the concentration and infrared transmitter easily.



# In-line Refractometer

## Model : GND15

### Product and accessories packing list

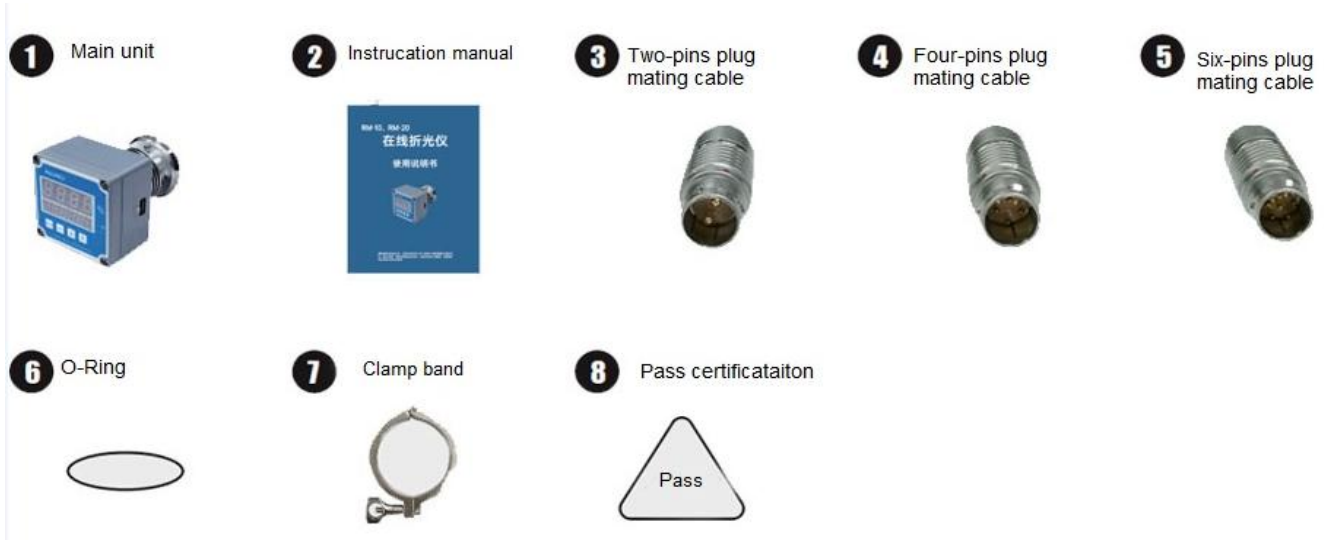

### Ordering Guide with \* are required, with --- is optional

Model	Range (%)	Output	Process connection	Electric connection	Accuracy	Other requirement
GND15	*	*	*	*	*	---
Example: GND15-33%-4-20mA-3" tri-clamp- 4pins -0.5%						

Producto Distribuido y Comercializado por ENAU Spa.  
 Diseñado por ZHYQ  
 Garantía de 12 Meses  
 E-mail: ventas@enau.cl  
 www.enau.cl

